

12/1

D-044

HISTORY X COUNT	DATE	ECN NO.	Rev.	REVISION	SIGN.

正式圖面
APR 26 2006
工程 部
捷泰精密工業股份有限公司

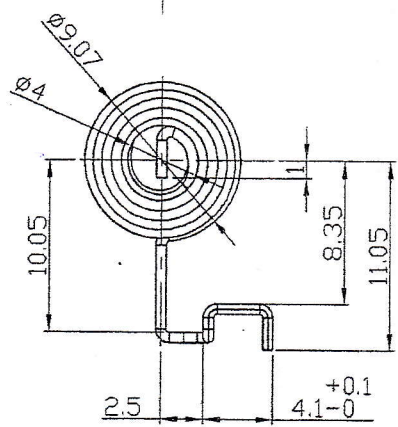
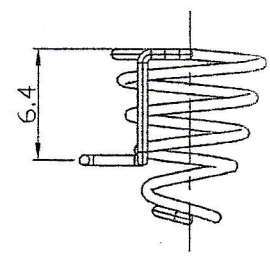
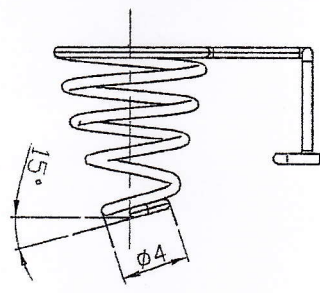
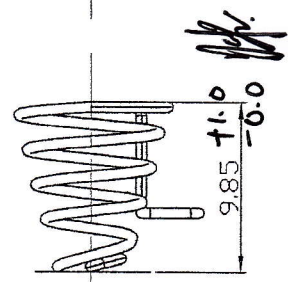
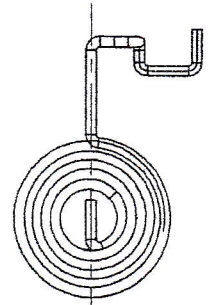

正式
參考
估價
發包
變更

發行單位
JTC
JTM
JTS
JTW

C Tol. SPECIFIED	
DIMENSION RANGE	Tol. ±
X ≤ 1	0.06
1 < X ≤ 8	0.10
8 < X ≤ 18	0.15
18 < X ≤ 50	0.20
50 < X ≤ 120	0.30
120 < X ≤ 250	0.40
250 < X ≤ 500	0.50

PE QC
PE QA
19 FEB 2016 19 FEB 2016
1 PS2

Norm Form		
	Negative pole	Positive pole
MATERIAL	SWIC-F	
Line(mm)	Ø 0.60	
Number of loops	5	
Direction	Left	
Total height (mm)	9.85	
Effective height (mm)	5.5±0.3	
Peak Force(N)	650±50	
The surface is dealt with	The deprease is dealt with	

PLATED/COLOR	ANGLE TOL. ±1°	SCALE 1:1	NOTICE
THICKNESS	TOLERANCE ±0.3	UNIT mm	
MATERIAL 鍍鎳線	ANGLE 3rd	ORIGINAL DATE '06.04.25	PART NAME TERMINAL
DESIGNED 吳金鴻	DRAWN	CHECKED 林水林	APPROVED 林水林 (代)
DATE 95.4.25	DATE 95.4.26	DATE 95.4.26	DATE 95.4.26
P/N: 101120001			Rev. 1.0
DWG. NO 7101-B010			SHEET 1/1
捷泰精密工業股份有限公司			SIZE A4
J.YE TAI PRECISION INDUSTRIAL CO., LTD.			

THIS DRAWING CONTAINS INFORMATION THAT IS PROPRIETARY TO J.T. AND CAN NOT BE REPRODUCED WITHOUT WRITTEN CONSENT OF J.T.