

正式	
參考	
估價	
發包	●
設變	

HISTORY X COUNT	DATE (YYYY.MM.DD)	ECN NO.	REV.	REVISION	SIGN.

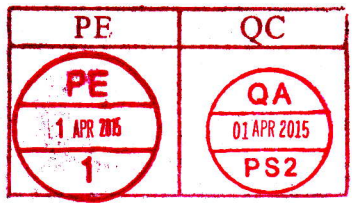
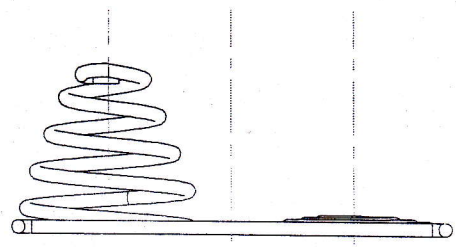
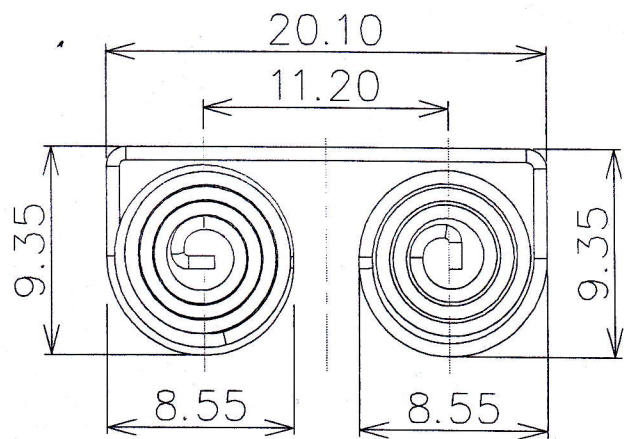
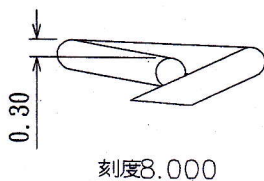

1. 材質需符合RoSh 相關規範
2. □ 符號量產管理
3. 需符合環境仕様要求.
4. 依據3D data製作加工.
5. 開模前務必確實檢討設計圖面, 若有疑問須向設計/工程人員確實討論.

要目表	
番號	136100001
品名	電池扣(負極)   電池扣(正極)
材料	鍍鎳線
線徑 (mm)	ø0.60
卷數	5.5   4.5
卷方向	右   左
自由長 (mm)	7.60 <sup>+0.30</sup>   —
有效高度(mm)	3.80±0.20   —
荷重(N)	3.62±0.49   —
表面處理	脫脂處理

鹽霧試驗條件	
飽合空氣桶溫度	47°C±1°C
壓縮空氣壓力	1±0.1Kg / cm <sup>2</sup>
噴霧量	1~2ml/80cm <sup>2</sup> /H
氯化鈉濃度	5±1%
試驗時間	48H

C	Tol. SPECIFIED
DIMENSION RANGE	Tol. ±
X ≤ 1	0.06
1 < X ≤ 8	0.10
8 < X ≤ 18	0.15
18 < X ≤ 50	0.20
50 < X ≤ 120	0.30
120 < X ≤ 250	0.40
250 < X ≤ 500	0.50

PLATED/COLOR	ANGLE TOL.	SCALE	NOTICE		
---	---	3.000			
THICKNESS	TOLERANCE	UNIT			
---	---	mm			
MATERIAL	ANGLE	ORIGINAL DATE (YYYY.MM.DD)	PART NAME	REV.	
---	3rd	2014.11.13	電池扣	A	
DESIGNED	DRAWN	CHECKED	APPROVED	PART NO	DWG. NO
				136100001	7136-B006
					SHEET 7/7
					SIZE A4
JYE TAI PRECISION INDUSTRIAL CO., LTD.					

THIS DRAWING CONTAINS INFORMATION THAT IS PROPRIETARY TO J.T. AND CAN NOT BE REPRODUCED WITHOUT WRITTEN CONSENT OF J.T.

19/11/2