

DRG. No. 1760-8114

SHEET 1 OF 1

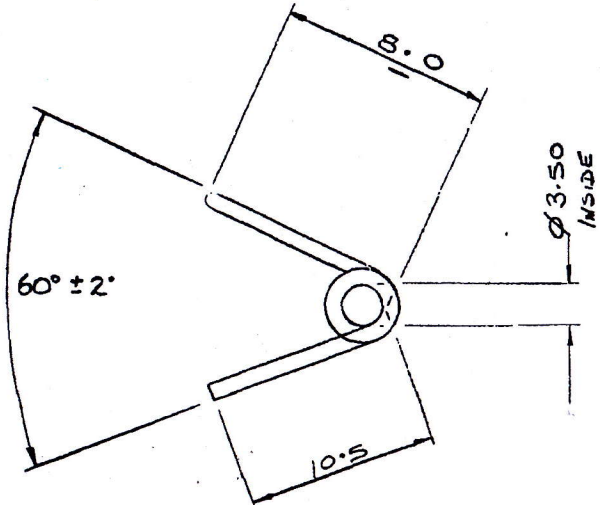
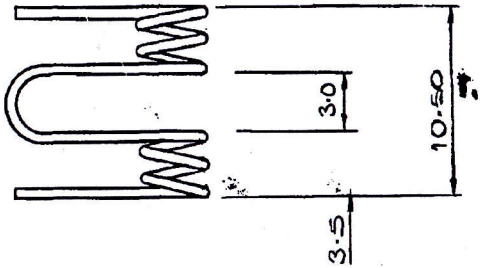
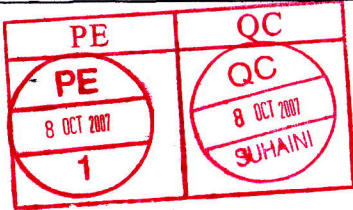

RECEIVED
OCT 2007

ISSUE	AMENDMENT	DATE
A		20-11-86
B		4-3-87
C		14-4-87
D	1/N 5452 Ltd 1/R 3838	19-4-87
E	PPCN P005	16-7-88
F	PPCN P013	18-3-88
G	PPCN P039	12-9-88
I	1.R 4060 1.N 5580	13-9-88

TOLERANCES UNLESS STATED OTHERWISE
 ± 0.4 TO 1 DEC. PLACE HOLES ± 0.05 UP TO 5 ± 1% ABOVE
 ± 0.2 TO 2 DEC. PLACES ANGLES ± 1/2°
 ± 0.1 TO 3 DEC. PLACES. CONCENTRICITY TO WITHIN 0.1 DIA.
 ALL THREADS TO BS 3843 PT. 2 1986 CLASS 6H - 6g

MATERIAL STAINLESS STEEL
 To BS 2056 302 B25
 20 SWG (0.9)

FINISH NONE

DIMENSIONS IN M M

SCALE

THIRD ANGLE PROJECTION

	NAME	DATE
DRAWN		20.11.86
CHECKED		30.4.87
APPROVED	W. Romax	1.5.87
APPROVED	C. P. [Signature]	1.5.87

SHEET 1 OF 1

Multitone Electronics P.L.C.
 © RESERVE THE COPYRIGHT OF THIS DRAWING WHICH IS NOT TO BE COPIED
 REPRODUCED OR DISCLOSED TO A THIRD PARTY WITHOUT WRITTEN CONSENT

TITLE SPRING

DRG.No. 1760-8114

A