

6 5 4 3 2 1

REVISIONS

ECN	LTR	DESCRIPTION	DATE	REVISED	APPROVED
-----	-----	-------------	------	---------	----------

MTR0006

UNLESS OTHERWISE SPECIFIED DIMENSIONS ARE IN MILLIMETERS INCHES TOLERANCE ON DECIMALS ±
 FRACTIONALS ± ANGLES ±
 DO NOT SCALE DRAWING

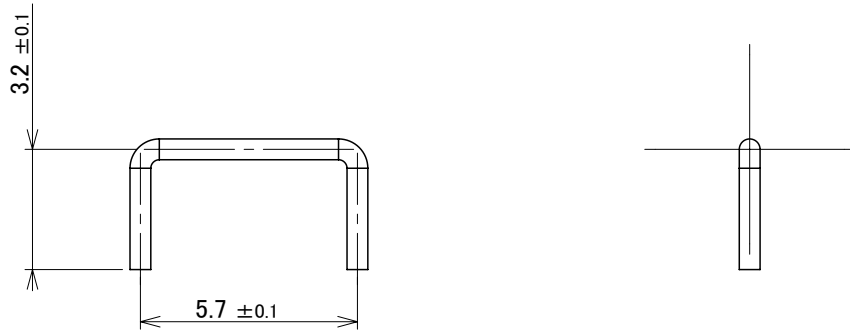

注) Notes

- 指示なき寸法公差は、±0.3とする。
Unless specified, the tolerance shall be ±0.3.
- 指示なき曲げRは、最小Rとする。
Unless specified, the curve R shall be the smallest R.
- 支障となる変形、傷、汚れ等のないこと。
There shall be no deformation, scratch, stain etc.on its appearance.
- 本製品の使用材料には、HTS A2106に準拠した材料を使用すること。
The material used for this product shall comply to HTS A2106.

MTR0006-650010		Ø 0.55 SWIC-F or KOSWIRE		REMOVE GREASE 脱脂	
LTR	PART NAME OR PART NO. 名称又は品番	QTY	MATERIAL 材質	TREATMENT 処理	
DWN	SHAHRI	DATE	Jun. 29'18	SCALE 5:1	NAME ジャンパーセンC部品図 JUMPER WIRE C PART DRAWING
CHKD	NAZRI	DATE	Jun. 29'18		
APVD	NAZRI	DATE	Jun. 29'18	3RD ANGLE PROJECTION	MODEL NO. MTR0006-01XXXX
Hosiden Corporation FACTORY: <input type="checkbox"/> OSAKA <input type="checkbox"/> TOKYO <input type="checkbox"/> KOBE <input type="checkbox"/> F.D. <input type="checkbox"/> TOHOKU <input type="checkbox"/> KYUSHU <input type="checkbox"/> SEIKO <input checked="" type="checkbox"/> HEM				DWG NO. MTR0006-650010PP	