

PRECISION SPRINGS (M) SDN. BHD.

DRAWING

CUSTOMER : BEYOND

PART NO ZHULIAN SPR 1	DESCRIPTION TORSION SPR	MATERIAL SUS 304 Ø 1.40MM	PROCESS NAME: COILING
---------------------------------	-----------------------------------	-------------------------------------	---------------------------------

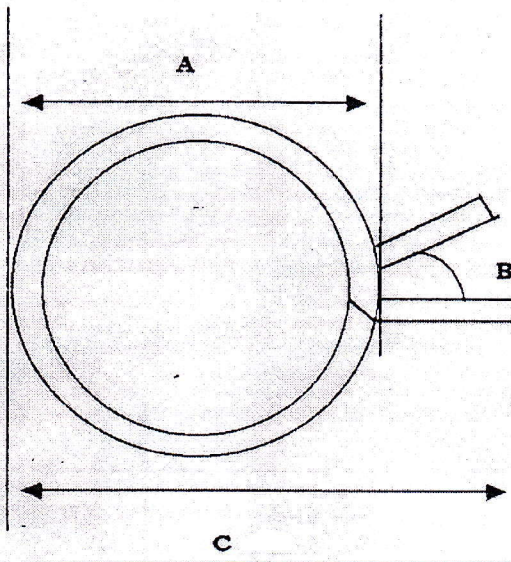

SPECIFICATION :

A : OUTSIDE Ø : 11.20	DIRECTION : LEFT
B : ANGLE : 70.0° +20° / -0°	TURNS : 3.15
C : LENGTH : 15.60MM	TEMPER : YES

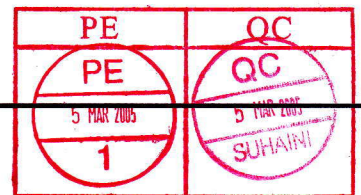

CHECK POINTS :-

VISUAL : NO DAMAGES AND NO SLUG MARKS

DIMENSIONS : ALL DIMENSION SHOULD BE CHECKED
DIMENSIONS TO BE RECORDED

METHOD OF CHECKING : VERNIER CALIPER & PROFILE PROJECTOR

PROCESS FLOW CHART:	REVISION NO: DOC:
PREPARED BY: JAYA DATE: 05.03.2005	CHECKED BY: DATE:
	APPROVED BY: DATE:

6hrs 25p