

4

3

2

1

REV.	ZONE	ECO NO.	REVISIONS-DESCRIPTION	DRFT	APPROVED	DATE
01	ALL		ENGINEERING RELEASE	PL		6/23/16
02			UPDATE MATERIAL SPEC	PL		9/16/16
03			FREE LENGTH AND ACTIVE COILS CHANGED	PL		6/19/17
04			DESIGN CHANGES	PL		7/10/17

NOTE:

- MATERIAL: OD 0.356 MM SST SPRING MATERIAL ,
OUTER DIAMETER=2.38
FREE LENGTH= 9.65
SOLID HEIGHT=3.81
TOTAL COILS=10
SPRING RATE= 13 LBS/IN
- BREAK ALL SHARP CORNERS
- FINISHED PART IS TO BE FREE OF ALL BURRS,DIRT AND OIL

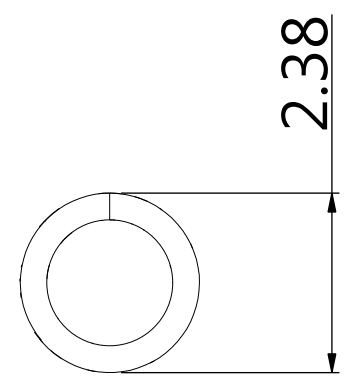
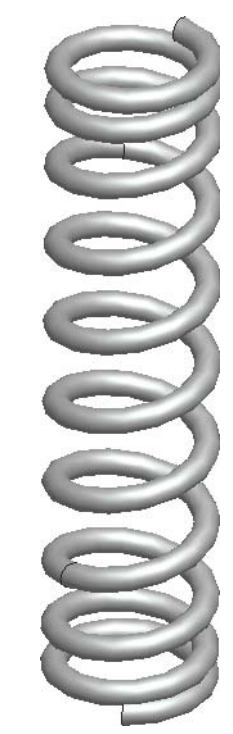
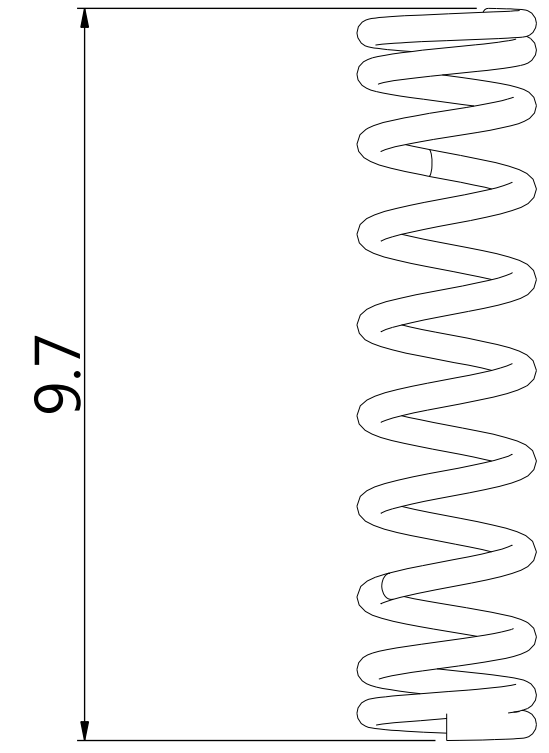

WHISTLE LAB CONFIDENTIAL
THIS DOCUMENT CONTAINS CONFIDENTIAL AND PROPRIETARY INFORMATION, AND EXCEPT WITH WRITTEN PERMISSION OF WHISTLE LAB SUCH INFORMATION SHALL NOT BE PUBLISHED OR DISCLOSED TO OTHERS OR USED FOR ANY PURPOSE OTHER THAN ON BEHALF OF WHISTLE LAB. THIS DOCUMENT SHALL NOT BE COPIED IN WHOLE OR IN PART, INCLUDING ELECTRONICALLY.

ITEM	QTY.	MATERIAL-DESCRIPTION	PART NUMBER
DO NOT SCALE DRAWING UNLESS OTHERWISE SPECIFIED DIMENSIONS ARE MM		DRAWN BY QENG	DATE 23-Jun-16
TOLERANCES: .X ± 0.20, .XX ± 0.100		CHECKED BY	Whistle
ANGLES: ±0.5		DSGN ENG QENG	
FIRST USED ON:		MFG ENG	TITLE WO3, COIL SPRING, ATTACHMENT
FINISH SEE NOTES	SCALE 10/1	FILE NAME 214-00513-00 .drw	C 214-00513-00- SHEET 1 OF 1
			REV 04

4

3

2

1

D

D

C

C

B

B

A

A