

環境の注記

当社の定めるグリーン調達ガイドライン (ホームページ参照) を遵守すること。

NOTES OF ENVIRONMENT

Conform to the Guideline for Green Procurement which our company defines.
(Refer to homepage)

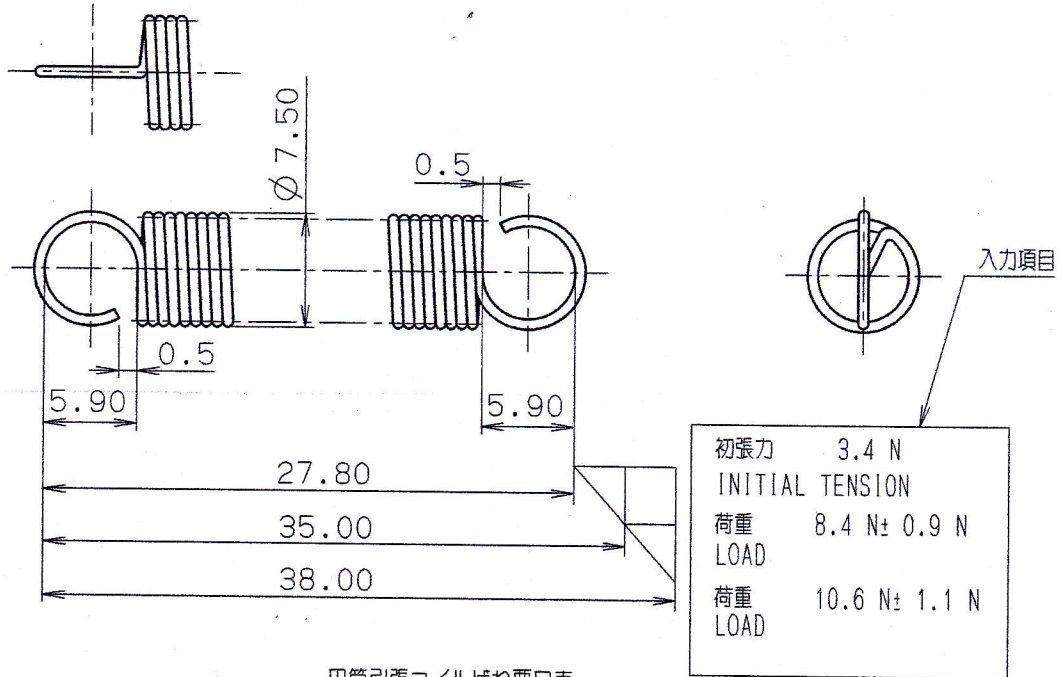

円筒引張コイルばね要目表
TABLE OF ESSENTIALS FOR CYLINDRICALLY COILED EXTENSION SPRING

巻き方 TYPE OF COILING	密着巻 SOLID COILING	フック形状 SHAPE OF HOOKS	逆丸フック REVERSED CIRCULAR HOOK	TYPE A
材料 MATERIAL	表題欄参照 SEE TITLE BLOCK	熱処理 HEAT TREATMENT	低温焼なまし LOW TEMPERATURE ANNEALING	
材料の直径 mm DIAMETER OF MATERIAL	0.80	防せい処理 RUST PREVENTIVE TREATMENT	-	
コイル外径 mm OUTSIDE DIAMETER OF COIL	7.50	ばね定数 N/mm SPRING RATE	0.7000	
有効巻数 ACTIVE COILS	19.00	最大応力 N/mm ² MAXIMUM STRESS	456	
巻方向 DIRECTION OF HELIX	自由 FREE			

MATERIAL: SWIC-F

SPEC./REMARKS: -
TREATMENT/FINISH: DEGREASING

PREVIOUS DRAWING NO.	REF MASS(g)	CALC VM(cm ³)	NAME
	3.2	0.4	SPG-BELT-TENS-RBT3

東芝テック株式会社
TOSHIBA TEC CORPORATION

SCALE	SIZE	PAGE	PROCESS	DRAWING NO.	BASIC CODE	SUB	REV
	A4	1/1	SPRING	6LK57809		0	00

PAGE COMBINATION LIST

NO.	ISSUE NO.
6	7
8	9
10	



QT RANK

C1

EDITED BY	DESIGN	CHECK	APPROVE	INITIAL ISSUE NO.
ADAM_NX	Y. KUBO			JVBXXXX
METRIC COUNT	MODIFY	CHECK	APPROVE	LATEST ISSUE NO.
mm				

USED IN

Main: Ref:

2017/11/5