

1 2 3 4

環境の注記
 当社の定めるグリーン調達ガイドライン（ホームページ参照）を遵守すること。

NOTES OF ENVIRONMENT
 Conform to the Guideline for Green Procurement which our company defines.
 (Refer to homepage)

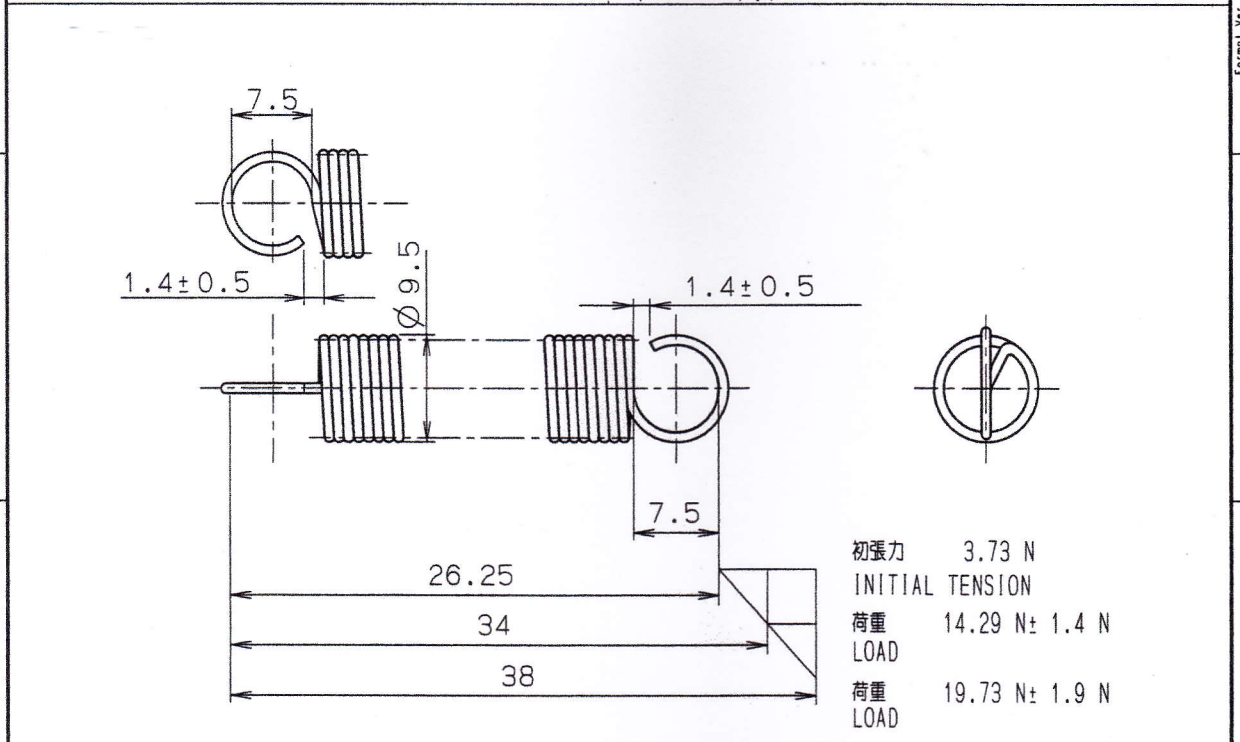

円筒引張コイルばね要目表
 TABLE OF ESSENTIALS FOR CYLINDRICALLY COILED EXTENSION SPRING

巻き方 TYPE OF COILING	密着巻 SOLID COILING	フック形状 SHAPE OF HOOKS	逆丸フック REVERSED CIRCULAR HOOK	TYPE A
材料 MATERIAL	表題欄参照 SEE TITLE BLOCK	熱処理 HEAT TREATMENT	低温焼なまし LOW TEMPRETURE ANNELING	
材料の直径 mm DIAMETER OF MATERIAL	1.0	防せい処理 RUST PREVENTIVE TREATMENT	XXXX	
コイル外径 mm OUTSIDE DIAMETER OF COIL	9.5	ばね定数 N/mm SPRING RATE	1.36	
有効巻数 ACTIVE COILS	10.25	最大応力 N/mm ² MAXIMUM STRESS	500.8	
巻方向 DIRECTION OF HELIX	自由 FREE			

注) 1. 脱脂処理の事
 NOTES) 1. TREATMENT MUST BE DEGREASE.

MATERIAL: SUS304-WPB

PREVIOUS DRAWING NO. REF MASS(g) CALC VM(cm³) NAME

4.7 0.6 SPG-E-PICK-SOL-H617

SCALE SIZE PAGE PROCESS DRAWING NO. BASIC CODE SUB REV

*: * A4 1/1 SPRING 6LK69888 0 00

東芝テック株式会社
 TOSHIBA TEC CORPORATION

PAGE COMBINATION LIST

NO.	ISSUE NO.	6
2	7	
3	8	
4	9	
5	10	

EDITED BY: T. IMAI
 ADAM_NX 2015/08/26

CHECK 2015/11/11 APPROVE 2015/11/11

INITIAL ISSUE NO. JVB46357

QT RANK C3

METRIC COUNT mm

CHECK APPROVE LATEST ISSUE NO.

USED IN
 Main: **FORMAL ISSUE** / JVB46357-20151111-1858

25/11/15