

REVISIONS

REV.	ECO NO.	BRADY Y NUMBER	DESCRIPTION OF CHANGE	REVISED BY	APPROVED BY	DATE
01	37839	Y4662893	MATERIAL CHANGE	GLADKOGE		
02		Y4662893	EM2 REVISION, REMOVED LHS E-RING	CHERNEKA		
03	37839	Y4662893	INCREASE PART LENGHT FOR STACKUP	TRAUTNPA		

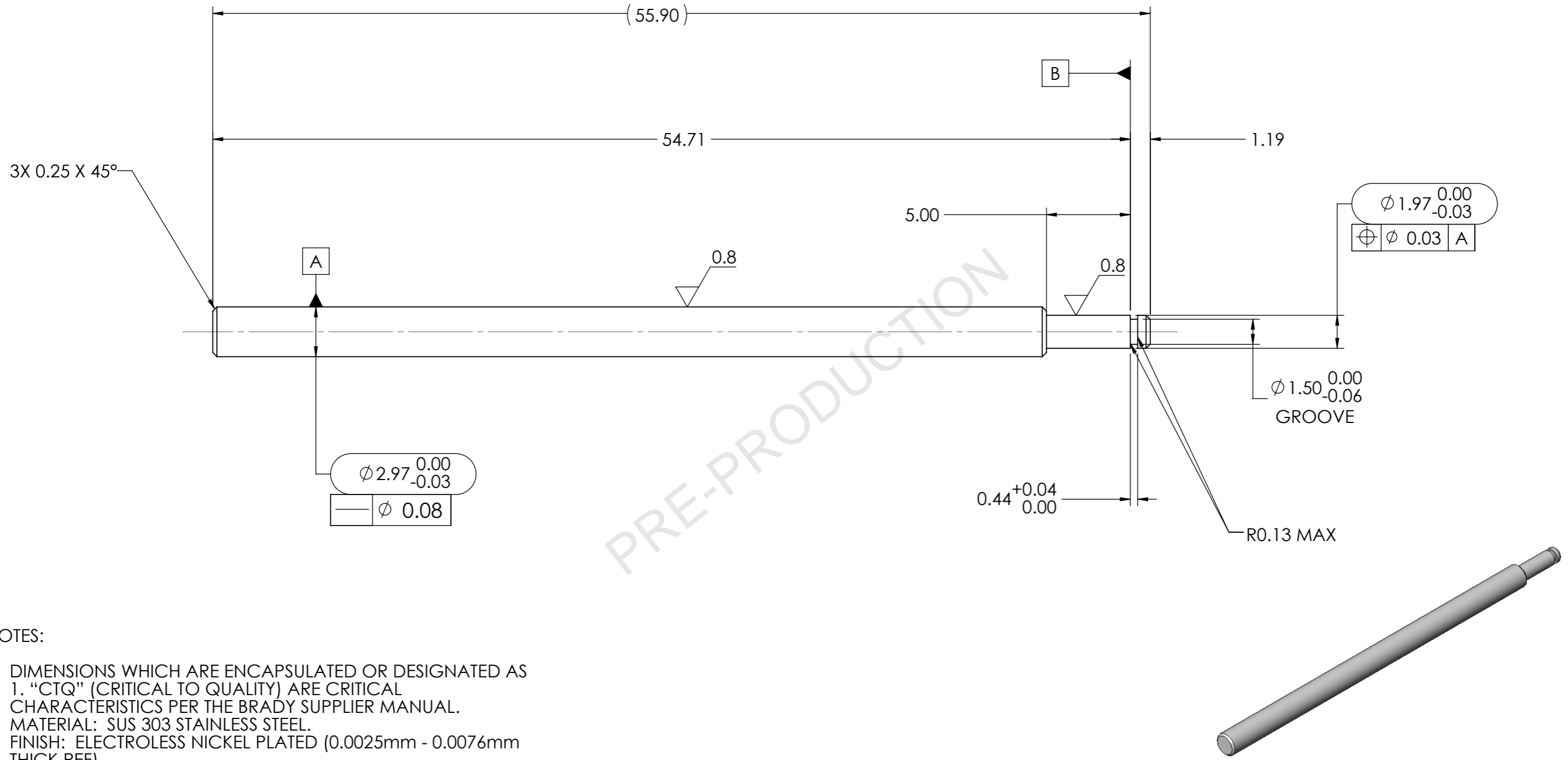

NOTES:

1. DIMENSIONS WHICH ARE ENCAPSULATED OR DESIGNATED AS 1. "CTQ" (CRITICAL TO QUALITY) ARE CRITICAL CHARACTERISTICS PER THE BRADY SUPPLIER MANUAL.
2. MATERIAL: SUS 303 STAINLESS STEEL.
3. FINISH: ELECTROLESS NICKEL PLATED (0.0025mm - 0.0076mm THICK REF)
4. PART TO BE FREE OF EXTERNAL BLEMISHES UNLESS APPROVED BY BRADY ENGINEERING.
5. CORNER BREAK/DEBURR ALL EXTERNAL EDGES UNLESS OTHERWISE SPECIFIED.
6. PART TO BE FREE OF OIL AND DIRT.
7. REFERENCE BRADY DOCUMENT SP00322/Y1321 FOR PACKAGING AND CLEANLINESS REQUIREMENTS.
8. COMPONENT MATERIALS NEED TO COMPLY WITH RoHS, REACH, 8. AND OTHER APPLICABLE REGULATIONS PER BRADY SYSTEMS SPECIFICATION SP00481/Y453647.
9. ALL DIMENSIONS ARE AFTER PLATING.

ENG. SPECIFICATIONS EXCEPT AS NOTED:
 DIMENSIONS ARE IN ACCORDANCE WITH ASME Y14.5Y-1994 INTERPRET DRAWING IN ACCORDANCE WITH ASME Y14.100
 UNLESS OTHERWISE SPECIFIED DIMENSIONS ARE IN MILLIMETERS
 DECIMALS: X. = ± 0.5
 .X = ± 0.25
 .XX = ± 0.13
 ANGLES: = ± 0°30'
 STANDARD MACHINING 3.2/√

THIRD ANGLE PROJECTION

 DO NOT SCALE

THE INFORMATION CONTAINED IN THIS DOCUMENT IS CONFIDENTIAL AND THE SOLE PROPERTY OF BRADY CORP. AND MAY NOT BE USED OR REPRODUCED WITHOUT THE WRITTEN PERMISSION OF BRADY CORP.

DWG BY GLADKOGE	PROJECT JUNIOR	SCALE 4:1	P.O. Box 2131 Milwaukee, Wisconsin 53201 Phone (414) 358-6600			
DATE 06/13/2018			MATERIAL SEE NOTES	SIZE A3	MODEL REV 02	STATUS EX
CHKD BY			FINISH SEE NOTES	SHEET 1 OF 1	DWG NO JNR40218	REV 03
DATE			DWG TITLE SHAFT, STUBBER, PEEL & PRESENT, JNR			

DRAWING DIR:000000000000000000041670 REVISION:03